

# User/Installation Manual



## REMOTEPRO KP MODEL 12-000SG



**“Your Partner in Access Control”**

[www.americanaccess.com](http://www.americanaccess.com)

## AAS 2Year Limited Warranty

**What item(s) this warranty applies to:**

American Access Systems RemotePro (12-XXXX series)" access controls..

**What is covered:**

Any defect in materials or workmanship.

**For how long:**

Two years from date of purchase.

**What we will do:**

If your AAS product is defective and returned within 2 years of the date of purchase, we will repair it or, at our option, replace it at no charge to you. If we repair your AAS product, we may use new or reconditioned parts. If we choose to replace your AAS product, we may replace it with a new or reconditioned one of the same or similar design. The repair or replacement will be warranted for (a) 90 days or (b) the remainder of the original two year warranty period, whichever is longer.

**Limitations:**

Implied warranties, including those of fitness for a particular purpose and merchant ability (an unwritten warranty that the product is fit for ordinary use), are limited to two years from date of purchase. We will not pay for loss of time, inconvenience, loss of use of your AAS product, service calls, or property damage caused by your AAS product or its failure to work, or any other incidental or consequential damages. Some states do not allow limitations on how long an implied warranty lasts or the exclusion or limitation of incidental or consequential damages, so the above exclusions or limitations may not apply to you.

**What we ask you to do:**

To get warranty service for your AAS product, you must provide proof of the date of purchase. Contact the original dealer or installer of the product and return your AAS product along with the receipt to them. If you have problems locating the dealer or installer contact American Access Systems at (303) 7999757 and we will direct you to an authorized dealer or distributor of American Access Systems products. If you ship your AAS product, you must prepay all shipping costs. We suggest that you retain your original packing material in the event you need to ship your AAS product. On return, include your name, address, phone number, proof of date of purchase, and a brief description of the operating problem.

**What this warranty does not cover:**

This warranty does not cover defects resulting from accidents, damage while in transit, alterations, unauthorized repair, failure to follow instructions, misuse, fire, flood, or acts of God. Nor do we warrant your AAS product to be compatible with any particular external device or peripheral. If your warranty has expired on your AAS product or if your product is NOT covered contact your dealer or installer for advice on whether we will repair your AAS product and other repair information, including estimated repair costs and other charges. We, at our option, may replace rather than repair your AAS product with a new or similar design if the damage to the unit is severe or extensive.

This warranty is the only one we give on this product, and it sets forth all our responsibilities regarding your AAS product. There are no other express warranties.

State Law rights:

This warranty gives you specific legal rights, and you may also have other rights which vary from state to state.



SECURITY BRANDS INC

**1675 West Yale Ave.  
Englewood, CO 80110**

**phone: 303-799-9757**

**fax: 303-799-9756**

**sales@securitybrandsinc.com**

**www.securitybrandsinc.com**

**Serial # \_\_\_\_\_**





**TECHNICAL/CUSTOMER SUPPORT  
1-303-799-9757 OR  
TECHSUPPORT@SECURITYBRANDSINC.COM**

## **BEFORE PROCEEDING**

To take full advantage of the 24 month limited warranty, you must be registered with American Access Systems. Please read the enclosed warranty statement, (pg 2), fill out the warranty registration card provided, and send it to:

**1675 West Yale Ave.  
Englewood, CO 80110  
phone: 303-799-9757  
fax: 303-799-9756  
sales@securitybrandsinc.com  
www.securitybrandsinc.com**



**SECURITY BRANDS INC**

## **INTRODUCTION**

Your new DKS unit is a high quality, commercial, digital key control station. The unit is designed to interface with the DKS control key station model numbers 24-100(i), 24-500(i), 24-1000(i) or any 26 bit Wiegand controller.



# STEP 1-MOUNTING THE UNIT

## Mounting the unit to your own pedestal

The 12-000sg is designed to mount in a standard 2 x 4 electrical box. Two security screws are provided to prevent tampering. American Access Systems can provide the proper tool to install these screws for an additional cost. They are standard (snake eyes) screws.

Once you have made your connections, fold the wires into the box and secure the keypad being careful not to pinch any wires between the box and keypad panel.

The 12-000f includes a flush mount back box to be inserted in whatever type of wall you are installing to. Use this box as a template to cut the proper size hole in the wall for mounting. You will have to drill your own mounting holes to secure the box in the wall.

# STEP 2-CABLING USING AAS 24-XXX MASTER

**CABLE TYPE: 6 CONDUCTOR TWISTED FOIL SHIELDED**

**(22 gauge BELDEN #9942)**

**MAX DISTANCE: 500 FEET**

Run 6 conductor twisted foil shielded cable between the 12-000 SLAVE and 24-100(i), 24-500(i), 24-1000(i), or 24-2000(i) MASTER. Keep the cable separated from high voltage 6" for every 110 volts. Connect the six conductor cable to the Master Keypad Terminal Board and 12-000 Harness. Refer to the Master keypad instructions for Weigand Color Codes.

The 12-000sg is designed to mount in a standard 2 x 4 electrical box. Two security screws are provided to prevent tampering. American Access Systems can provide the proper tool to install these screws for an additional cost. They are standard (snake eyes) screws.

Once you have made your connections, fold the wires into the box and secure the keypad being careful not to pinch any wires between the box and keypad panel.

The 12-000f includes a flush mount back box to be inserted in whatever type of wall you are installing to. Use this box as a template to cut the proper size hole in the wall for mounting. You will have to drill your own mounting holes to secure the box in the wall.

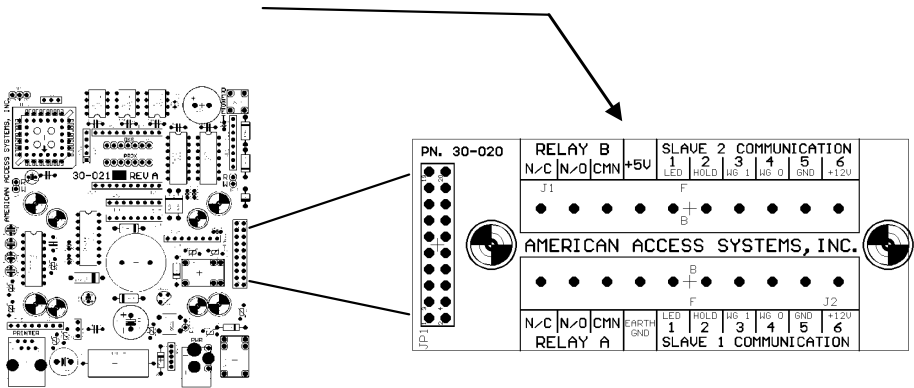

## THE IDLE MODE

The idle mode is the mode of operation in which the unit sits and waits for data from the keypad. When a key is pressed you will have approximately 3 seconds between keypresses before the unit resets.

## THE LED's

The yellow LED serves as a ready indicator and stays lit while the 12-000 is waiting for data from the keypad. When a key is pressed the yellow led will go out until either 5 numeric keys are pressed on the keypad or a time of 3 seconds is exceeded between keypresses. The red LED will light when a valid code is entered from the slave.

## THE \* AND # KEYS

The \* and # keys both serve as clear keys and should be used if an entry error is made. A double beep will be heard from the unit when either key is pressed.

## ENTERING DATA

A beep will be heard from the unit when a numeric key is pressed. You may enter any 5 digit code from the keypad from 00000 to 65534. If a number greater than 65534 is entered, the unit will error internally and data will not be transmitted from the unit.

## THE DIP SWITCHES

The dip switches are not utilized if you are interfacing the 12-000(i) slave to an AAS DKS system and all the dip switches should be set to off. Should you be interfacing the slave to a 3rd party system, contact American Access Systems for the appropriate dipswitch programming instructions.

## STEP 2-A- CABLING USING OTHER WIEGAND CONTROLLERS

Run 6 conductor twisted foil shielded cable between the REMOTE PRO Slave and the Master. Keep the cable separated from high voltage 6" for every 110 volts. The Remote Pro Slave operates on 6 VDC minimum and 12 VDC maximum. Measure your voltage from the source and make sure it falls within these tolerances. Locate the Wire Harness on the Remote Pro Slave. The circuit board end of the cable is keyed and can only be plugged into the circuit board one way. **DO NOT FORCE THE CONNECTOR.** Follow the color code chart below for hookup.

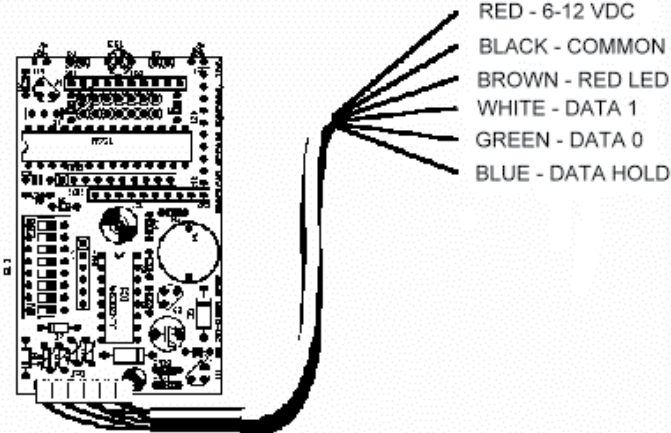

## THE IDLE MODE

The idle mode is the mode of operation in which the unit sits and waits for data from the keypad. When a key is pressed you will have approximately 3 seconds between keypresses before the unit resets.

## THE LED'S

The yellow/green LED serves as a ready indicator and stays lit while the REMOTE PRO is waiting for data from the keypad. When a key is pressed the yellow/green led will go out until either 5 numeric keys are pressed on the keypad or a time of 3 seconds is exceeded between keypresses.

## THE \* AND # KEYS

The \* and # keys both serve as clear keys and should be used if an entry error is made. A double beep will be heard from the unit when either key is pressed.

## ENTERING DATA

A beep will be heard from the unit when a numeric key is pressed. You may enter any 5 digit code from the keypad from 00000 to 65534. After a code has been entered the unit transmits two codes, a facility or site code and the numeric code entered from the keypad. The facility or site code is programmed via the dip switches on the board (See page 4.) If a number greater than 65534 is entered, the unit will error internally and data will not be transmitted from the unit.

## THE DIP SWITCHES

The Remote Pro line incorporates a facility or site code programmable from 0 to 255 via the dip switches on the circuit board. When a code is entered from the keypad, 2 different codes are transmitted from the Remote Pro. The facility code, and the keypad code itself. The facility code can therefore be used to identify which keypad is sending the code in a multiple door layout. The facility code allows up to 256 different units to be uniquely identified in a system. Each dip switch corresponds to a specific number. Switch 1 = "1", 2="2", 3="4"..... 8="128". The facility code is set by turning dip switches on and then adding their values together. For example, if you wished to set the facility code to "131", you would set dipswiches 1,2, and 8 to on.

### EXAMPLE

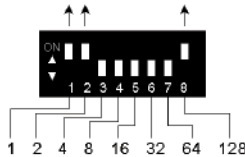

$$"1" + "2" + "128" = 131$$

### TIMING SIGNALS

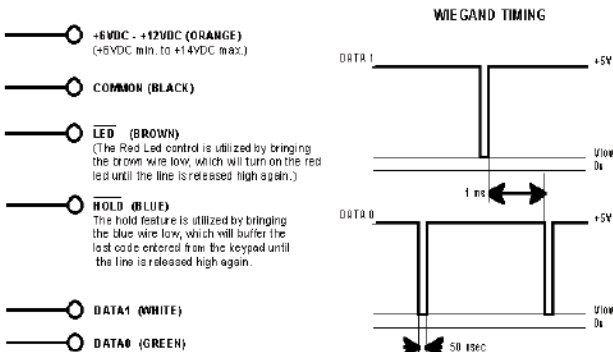

# CUSTOMER SERVICE AND TECH SUPPORT

## Customer Service: 303-799-9757

Customer service is available free of charge. Hours are 8:00 a.m. to 4:30 p.m. MST. If you call, please have your Model and Serial Number to help our Technicians assist you.

E-Mail: [customerservice@securitybrandsinc.com](mailto:customerservice@securitybrandsinc.com)

## Technical Support: 303-799-9757

Technical support is available free of charge. Hours are 8:00 a.m. to 4:30 p.m. MST. If you call, please have your Model and Serial Number to help our Technicians assist you.

E-Mail: [techsupport@securitybrandsinc.com](mailto:techsupport@securitybrandsinc.com)



SECURITY BRANDS INC

**1675 West Yale Ave.  
Englewood, CO 80110**

**phone: 303-799-9757**

**fax: 303-799-9756**

**[sales@securitybrandsinc.com](mailto:sales@securitybrandsinc.com)**

**[www.americanaccess.com](http://www.americanaccess.com)**



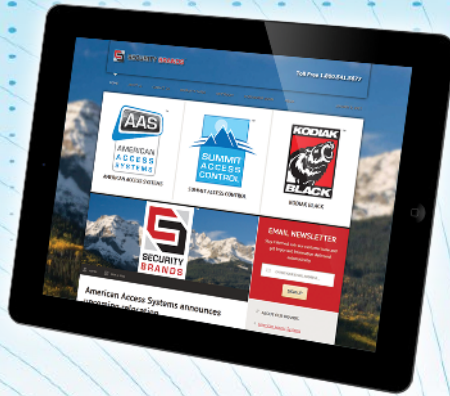

**“YOUR PARTNER IN  
ACCESS CONTROL”  
[WWW.SECURITYBRANDSINC.COM](http://WWW.SECURITYBRANDSINC.COM)**



**SECURITY BRANDS INC**