



1 Unpack box and make sure you have everything shown here.

RTE Unit (includes battery)	Key Switch Keys (may look different)	Lock Key	Carriage Bolt (4x)	Hex Nut (4x)	Hole Plug	Screwdriver

What's what?

Important components labeled

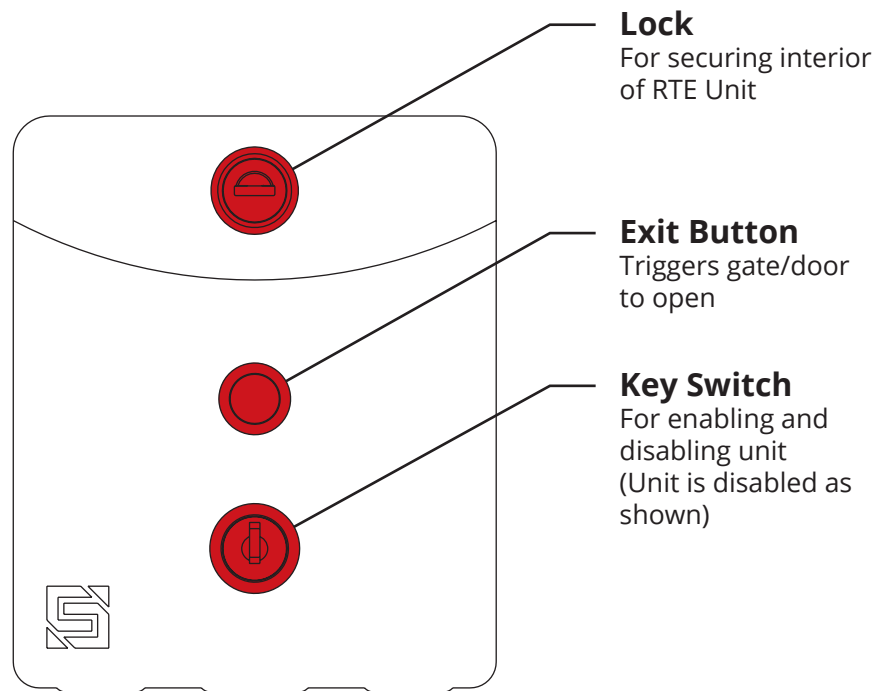

RTE Unit Faceplate (Front)

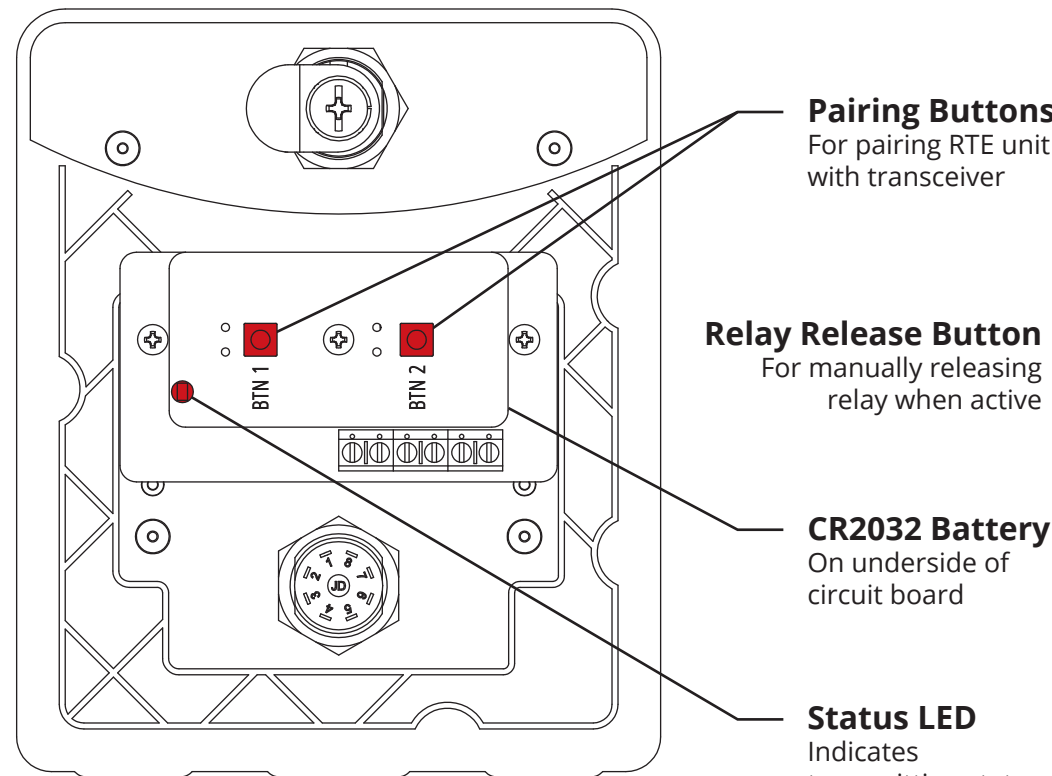

RTE Unit Faceplate (Back)
Internal wiring not shown for clarity.

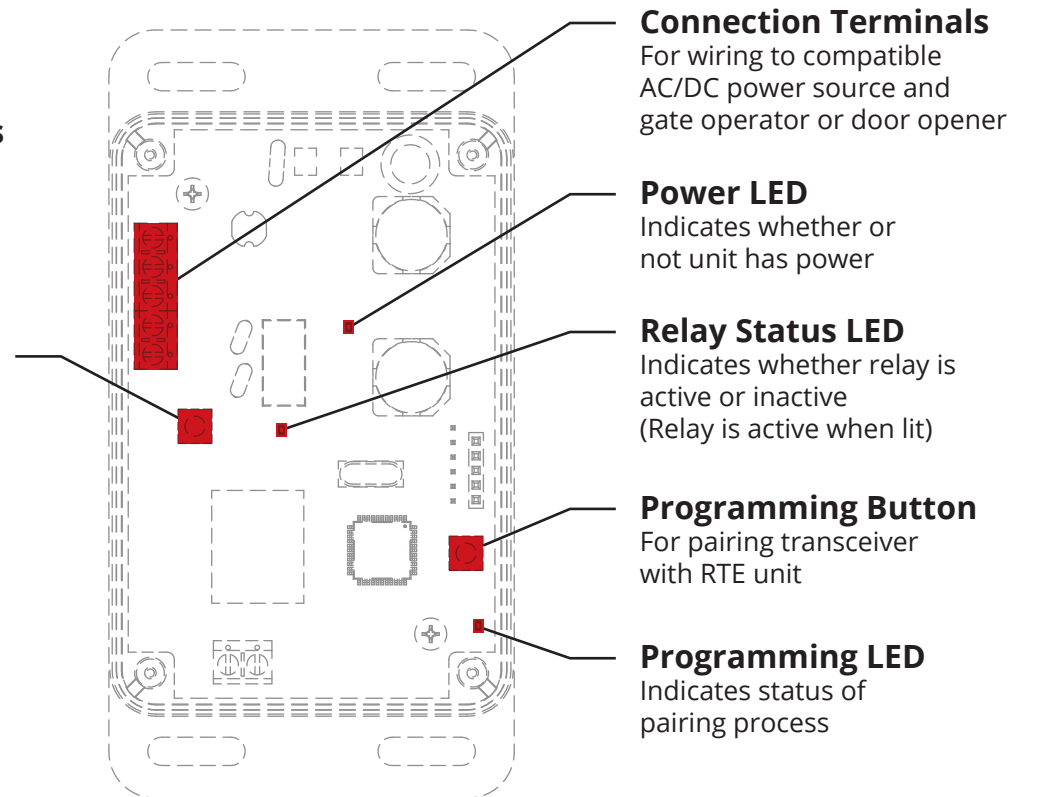

Transceiver (Sold Separately)
Shown with cover removed. Internal wiring not shown for clarity.

2 Unlock and remove faceplate of RTE unit; then using included carriage bolts and hex nuts, attach unit to pedestal as shown.

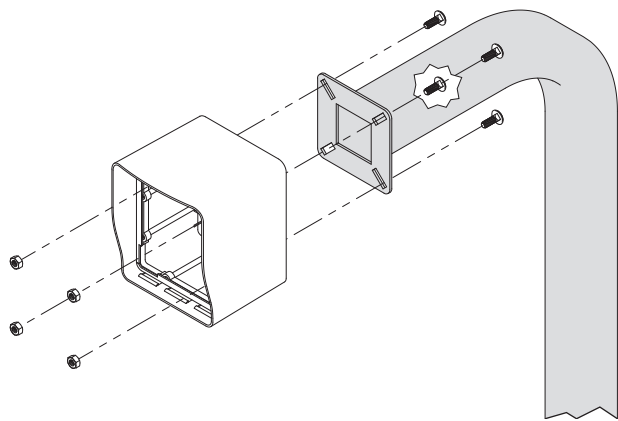

3 Using Tek screws, zip ties, or other means of securing, attach transceiver to inside wall or other surface inside gate operator.

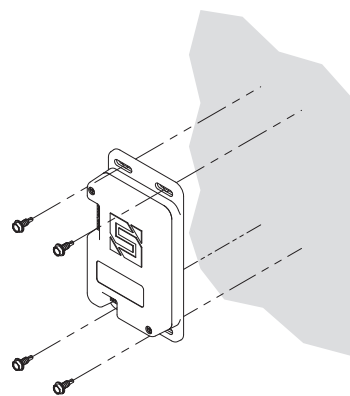

CAUTION

The transceiver is not weatherproof and must be mounted inside a weatherproof enclosure. Internal components can be damaged if exposed to the elements.

Failure to comply will VOID WARRANTY.

WARNING

AUTOMATIC GATES CAN CAUSE SERIOUS INJURY OR DEATH!
ALWAYS CHECK THAT THE GATE PATH IS CLEAR BEFORE OPERATING!
REVERSING OR OTHER SAFETY DEVICES SHOULD ALWAYS BE USED!

4a Connect transceiver

Gate Operator Timer-to-Close
OFF

Ridge Transceiver

Gate Operator / Door Opener

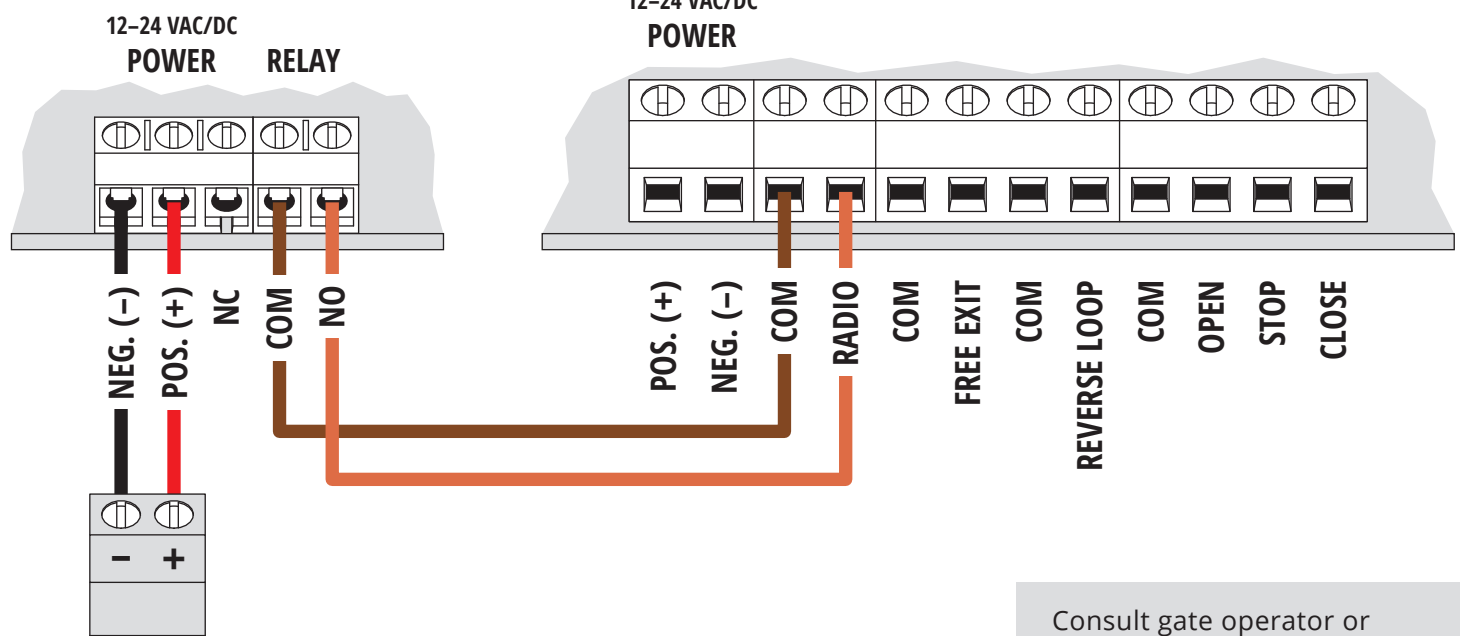

12-24-VAC/DC Power Source (Not Included)

Consult gate operator or door opener manual for exact connections. Terminals vary widely across manufacturers and models.

4b Connect transceiver

Gate Operator Timer-to-Close
ON

Ridge Transceiver

Gate Operator / Door Opener

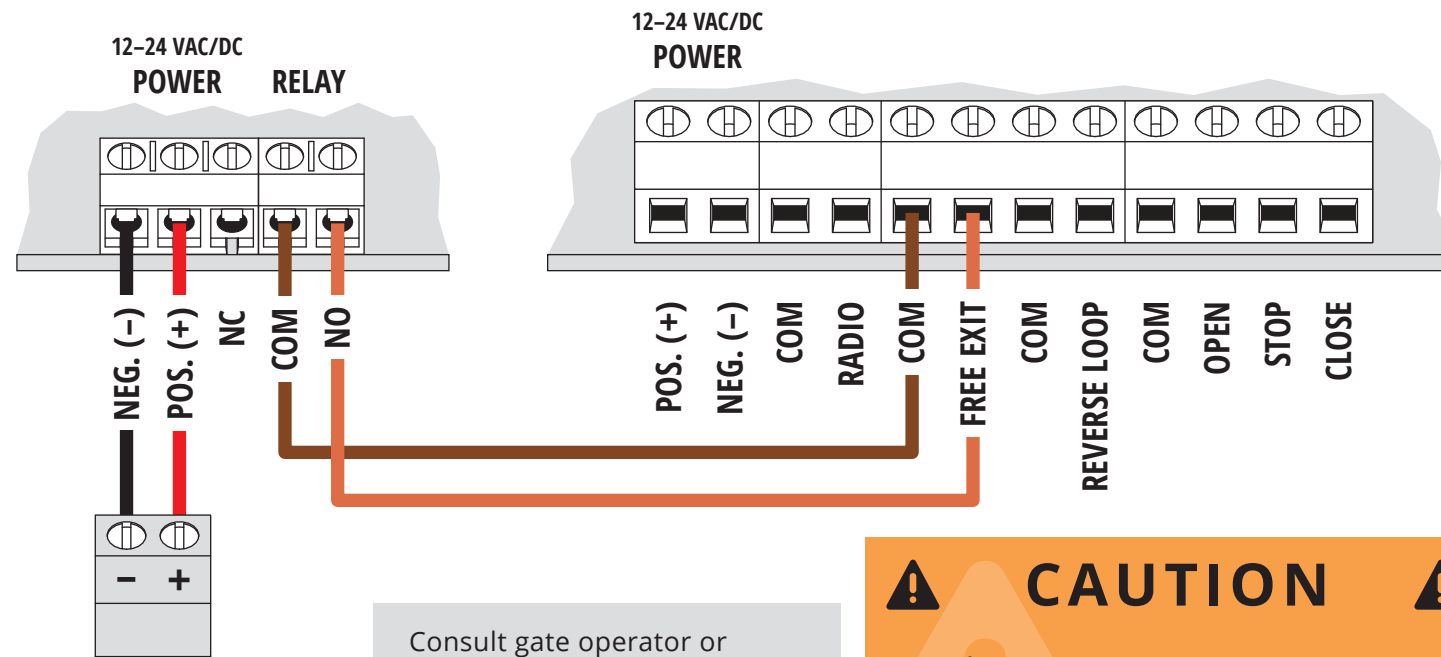

12-24-VAC/DC Power Source (Not Included)

Consult gate operator or door opener manual for exact connections. Terminals vary widely across manufacturers and models.

CAUTION

A closing gate can cause injury to persons or damage to property.

ALWAYS USE SAFETY DEVICES!

5a Remove transceiver cover; then hold down Programming Button on circuit board for 5 seconds and let go.

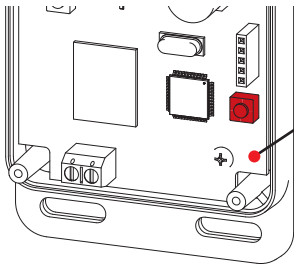

LED will light and stay on

5b Remove RTE unit faceplate.

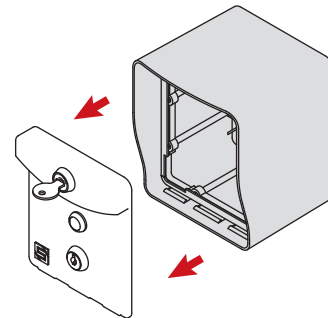

5c Hold down both Pairing Buttons until Status LED flashes. Let go of Button 2, and continue holding Button 1 only until Status LED flashes again.

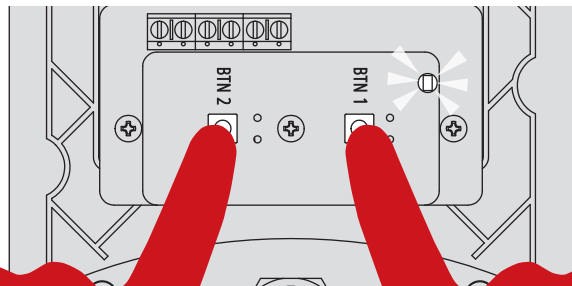

! CHECK THAT THE GATE PATH IS CLEAR BEFORE COMPLETING THIS STEP AS IT TRIGGERS THE RELAY!

5d Relay on transceiver should click and Programming LED should go out. Pairing is now complete.

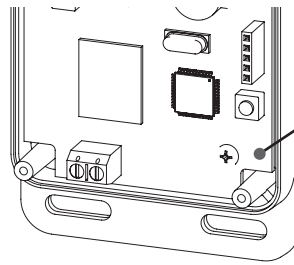

LED will go out

6 Press Exit Button on RTE unit and confirm gate/door opens. (If nothing happens, repeat Step 5. If gate/door is held open, see Troubleshooting section on Page 4.)

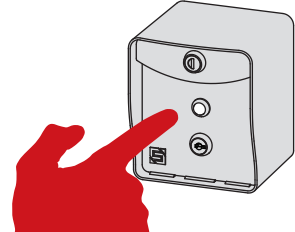

! CHECK THAT THE GATE PATH IS CLEAR BEFORE COMPLETING THIS STEP AS IT TRIGGERS THE RELAY!



INSTALLATION COMPLETE!

Your system is ready to use.

A The RTE unit can be disabled and re-enabled at any time by taking the key switch keys and using the Key Switch located below the Exit Button.

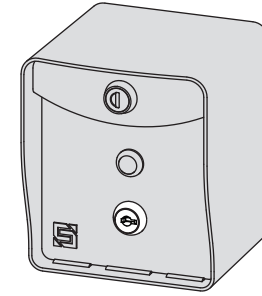

Unit Enabled
(Exit Button active)

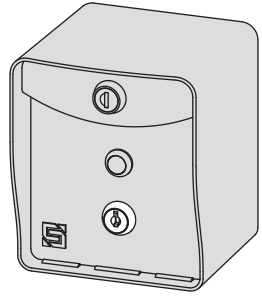

Unit Disabled
(Exit Button inactive)

B **Reset Procedure (Transceiver)**

IMPORTANT: FOLLOWING THIS PROCEDURE WILL UNPAIR ALL DEVICES (KEYPADS, RTEs, AND REMOTES) FROM THIS UNIT!

NOTE: Transceiver must have power.

Step 1 - Remove screws and remove transceiver cover.

Step 2 - Press and hold Programming Button until Programming LED starts to flash. Button must be held for about 30 seconds. Once flashing stops, all devices have been unpaired from transceiver and reset is complete.

Step 3 - Replace transceiver cover and secure screws.

C Troubleshooting

Gate/door is being held open

IMPORTANT: GATE/DOOR MUST BE CLOSED BEFORE COMPLETING THIS PROCEDURE!

NOTE: Unit must have power.

Step 1 - Press Exit Button on RTE unit to close gate/door if it is not already closed.

Step 2 - Hold down both Pairing Buttons and pay attention to Status LED.

Step 3 - When Status LED flashes twice, continue holding BOTH buttons.

Step 4 - When LED flashes twice again, continue holding Button 1 ONLY until Status LED flashes multiple times.

Now the RTE unit should only hold the gate/door open momentarily.

NOTE: If gate/door is still held open and Relay Status LED is lit on transceiver, press Relay Release Button to release hold.

NOTE: If gate/door is still held open, contact a gate/door specialist.

Gate/door is opening/closing without input from RTE unit

Complete Section B to reset transceiver.

RTE unit has limited range

IMPORTANT: DISCONNECT FROM POWER BEFORE COMPLETING THIS PROCEDURE!

Step 1 - Check position of blue wire coil on transceiver. It should be secured in the terminal block labeled "ANTENNA" and, if you unscrew and flip the circuit board over, this should correspond to the position above five-hole pattern.

Step 2 - If antenna wire coil is in wrong position, unscrew terminal block, move wire coil to next terminal block, and screw down to secure.

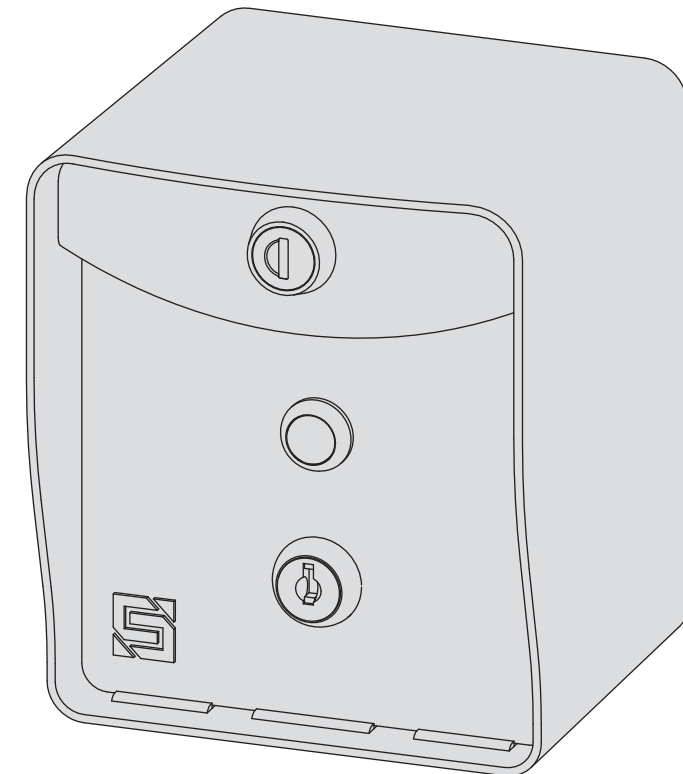

Ridge RTE
14-RTE433T



Call (972) 474-6422

Email support@summitcontrol.com

We are available **Mon-Fri / 8am-5pm Central**



SECURITY BRANDS INC