

START HERE →

1 Carefully unpack box.

2 Make sure you have everything shown here.

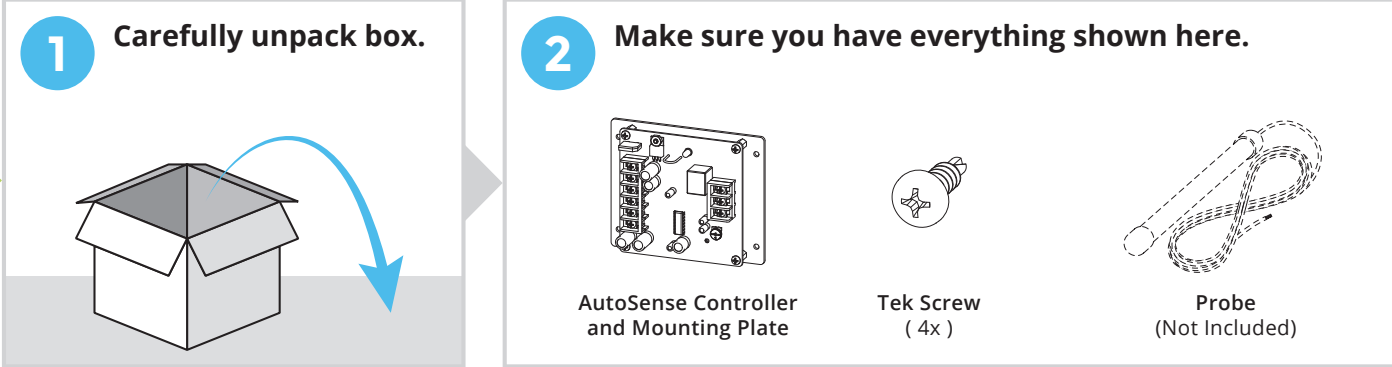

AutoSense Controller and Mounting Plate Tek Screw (4x) Probe (Not Included)

What's what?

Important components labeled

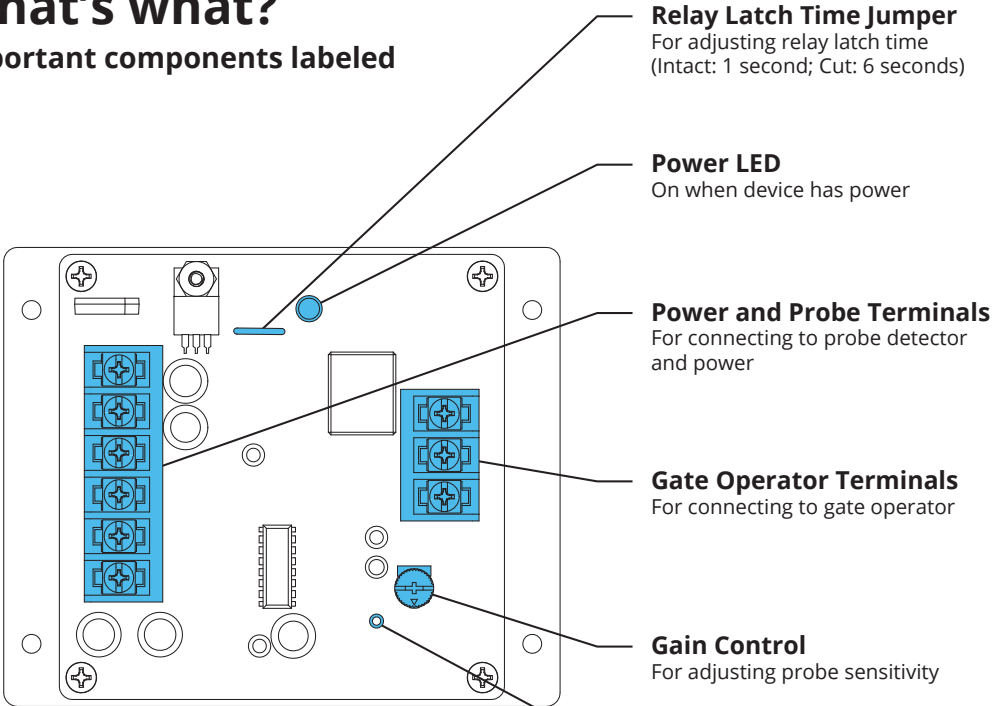

- Relay Latch Time Jumper**
For adjusting relay latch time
(Intact: 1 second; Cut: 6 seconds)
- Power LED**
On when device has power
- Power and Probe Terminals**
For connecting to probe detector and power
- Gate Operator Terminals**
For connecting to gate operator
- Gain Control**
For adjusting probe sensitivity
- Test Point (T.P.)**
For diagnostic testing

AutoSense Controller and Mounting Plate

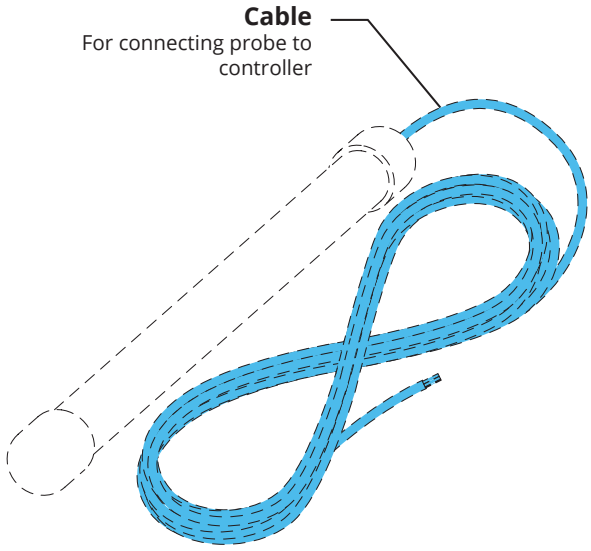

Cable
For connecting probe to controller

Probe
(Not Included)

Continued on next page...

! WARNING!

AUTOMATIC GATES CAN CAUSE SERIOUS INJURY OR DEATH!

ALWAYS CHECK that the GATE PATH IS CLEAR BEFORE OPERATING!

REVERSING or other SAFETY DEVICES SHOULD ALWAYS BE USED!

3 Connect wires

After reading previous section entitled Installation Considerations, connect wires as shown.

Earth ground should not be connected until final installation.

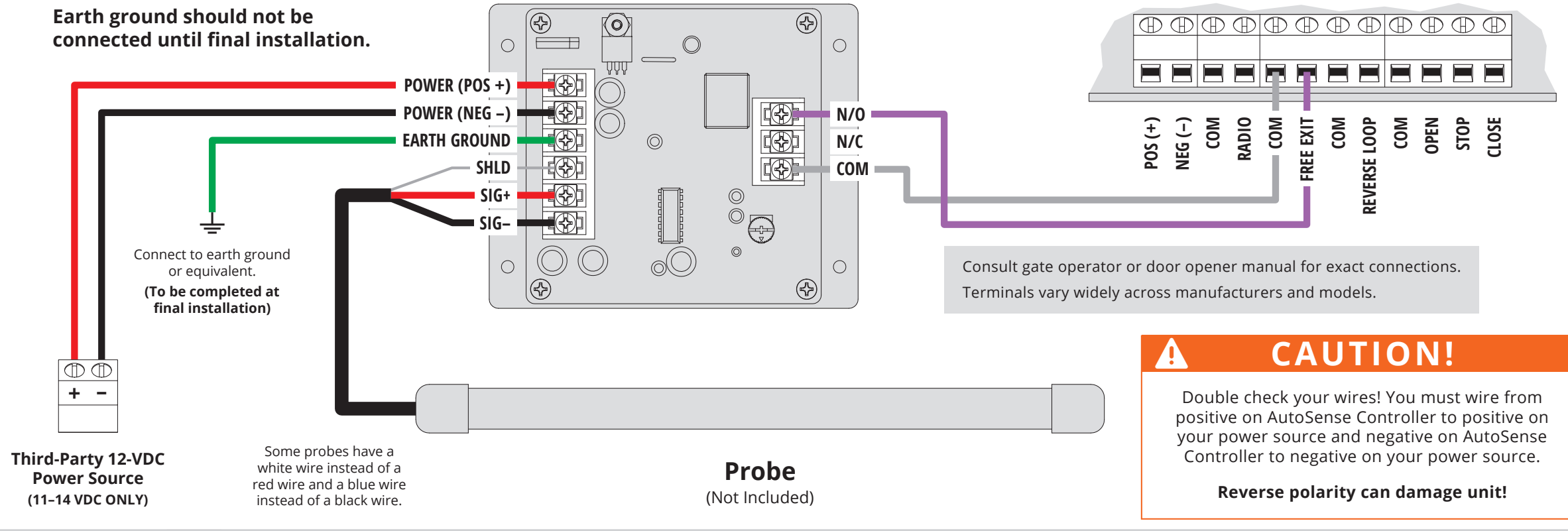

Third-Party 12-VDC Power Source (11-14 VDC ONLY)

Some probes have a white wire instead of a red wire and a blue wire instead of a black wire.

Probe (Not Included)

CAUTION!
 Double check your wires! You must wire from positive on AutoSense Controller to positive on your power source and negative on AutoSense Controller to negative on your power source.
Reverse polarity can damage unit!

4 Turn Gain Control on controller counter-clockwise until it stops to set sensitivity to minimum gain.

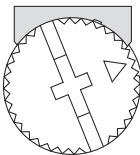

5 Connect multimeter between N/O and COM terminals on controller and check resistance (Ω).



The multimeter will read OL (over limit) until the probe is activated because the relay circuit is open.

6 After power has been applied for 3 minutes, move probe at least 4 feet from controller, and activate by waving metal object down its length. Verify contact closure with meter.



Suitable metal objects include screwdrivers, wrenches, or other metal tools. The multimeter will read less than 10 Ω when the probe is activated.

7 Perform field testing

NOTE: THIS PROCEDURE SHOULD BE DONE IN THE FIELD, PREFERABLY AT THE INSTALL LOCATION.

Step A - Connect wires as in Step 3.

If more than one probe is being used, please reference the figure entitled *Connecting Probes in Series*. Up to five probes can be supported by one controller.

Step B - Wait at least 3 minutes.

Step C - Place the probe(s) on the ground in the desired location. Please see the chart entitled *Approximate Detection Radius*.

Step D - Turn the Gain Control on the controller counter-clockwise until it stops to set minimum gain.

Step E - Drive past the probe(s) at the slowest probable speed. Gradually increase sensitivity with the Gain Control until vehicle movement is consistently detected by the probe(s).

Be sure the detection range extends to the furthest edges of the desired area. If the detection area is too small, enlarge it by adding one or more probes in series, as shown. If the detection area is too large, move the probe(s) further away from the vehicle path.

NOTE: TO ENSURE RELIABLE VEHICLE DETECTION, DO NOT INCREASE SENSITIVITY BEYOND WHAT IS NECESSARY.

Connecting Probes in Series

For increasing detection area

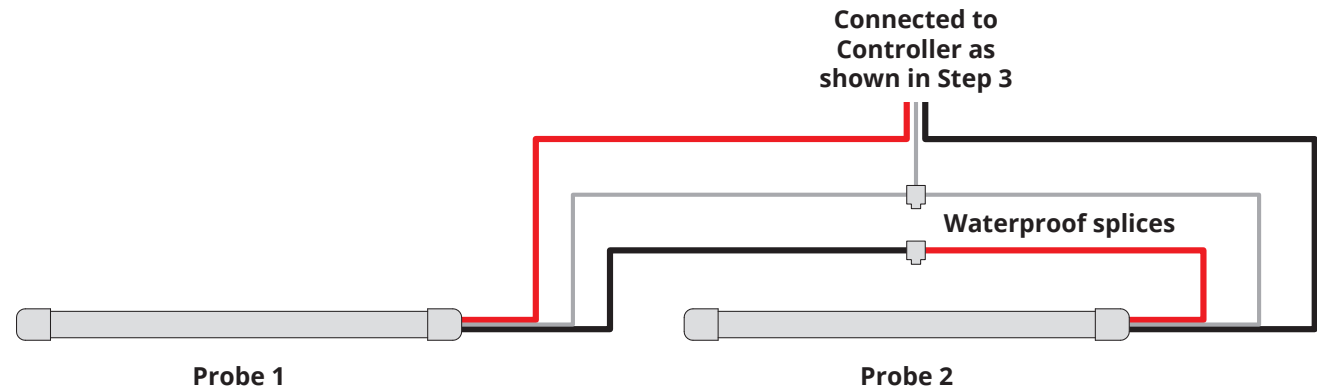

8 Using included adhesive strips or Tek screws, attach AutoSense Controller to wall or other surface inside gate operator, door opener, or suitable enclosure.

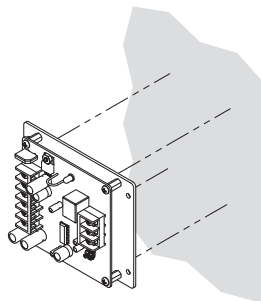

Approximate Detection Radius

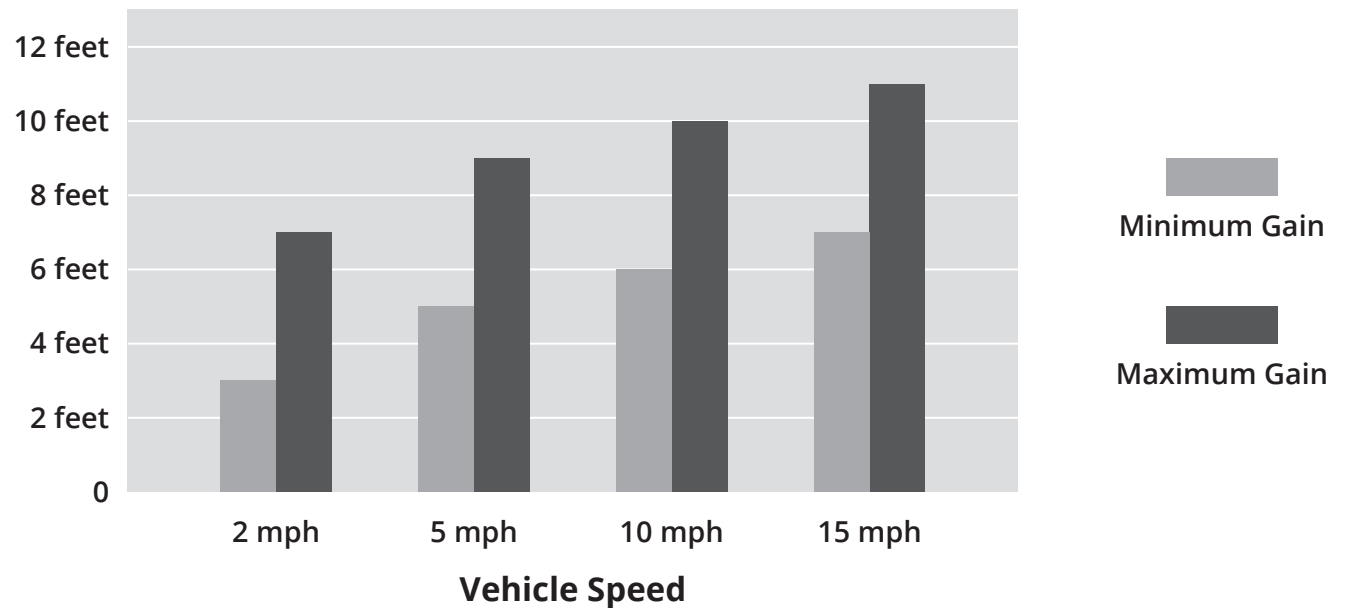

Installation Considerations

General

If your probe does not have enough cable for your installation, it is better to get one that does. If you absolutely must splice, first solder the wires to be spliced, then use a good quality direct-burial waterproof splice.

To avoid nuisance tripping of the AutoSense Vehicle Detector, do not install the probe or probe cable within 8 feet of power lines, mercury lights, electric motors, or intermittent pumps. It is important to keep the probe as far away from utility lines, transformers, or electrical transients as possible.

Remember the mass and speed of vehicles results in a relatively large-diameter detection area. The probe should not be installed closer than 30 feet to a busy residential street, 40 feet to truck traffic, or 100 feet to railroad tracks.

It is essential that the waterproof integrity of the probe-and-cable assembly is maintained. A nicked or crushed cable jacket may allow moisture to enter the cable or probe, resulting in intermittent and unreliable operation. Damaged wire can be cut out and spliced (check the resistance of the remaining cable first to ensure it is free of moisture).

In order to protect the cable from burrowing animals (moles, etc.), we recommend running the cable in 1/2-inch thick-wall PVC conduit at about 18 inches deep. This will also offer some protection from rototillers and irrigation-line trenchers. If the probe or cable will be buried in dirt or gravel, the use of conduit will prevent sharp stones from puncturing the cable jacket.

The controller must have a good earth ground in order to provide consistently reliable operation. A metal cold-water pipe (street side) or a 5-foot copper rod will provide the best results.

Probe Installation Next to a Driveway

Determine the optimum placement by laying the probe on the ground, turning the Gain Control (sensitivity) on the controller all the way down (counter-clockwise), and driving past the probe at the probable speed and line of travel. Gradually increase the sensitivity and/or adjust the probe location for better results. Keep the sensitivity as low as possible to avoid nuisance tripping. Bury the probe 6 to 12 inches deep, parallel to the line of travel of the vehicle. If the probe is placed in conduit (1-1/2-inch ID), use foam, sponge, or tape to ensure it does not move within the conduit.

Probe Installation in a Driveway

Place the probe in the middle of the driveway, perpendicular to the line of travel of vehicles. It should be at least 1 inch under the surface of concrete (above any rebar or metal mesh) and 2 inches under asphalt. It can be positioned properly before the driveway is poured or paved, or cut can be made in an existing driveway to accommodate the probe and cable.

The probe and cable should be enclosed in plastic pipe to facilitate replacement if required. Use foam, sponge, or tape to ensure the probe does not move within the pipe.

If the driveway is a two-car driveway, two probes wired in series may be necessary for complete coverage.

Other Applications

The AutoSense Vehicle Detector can be used for other applications and in other physical configurations. Please contact Security Brands at **(972) 474-6390**, or visit our website at securitybrandsinc.com

Product Specifications

Input Power	11-14 VDC
Current Draw	less than 15 mA standby, 35 mA detect
+ DC Output	10 VDC, 100 mA, unregulated

Relay Contact Rating	3 A @ 28 VDC
Relay Latch Time	approximately 1 or 6 seconds
Operating Temperature	0 to 120 °F



WARNING!

**AUTOMATIC GATES CAN CAUSE
SERIOUS INJURY OR DEATH!**

**ALWAYS CHECK that the GATE PATH IS
CLEAR BEFORE OPERATING!**

**REVERSING or other SAFETY DEVICES
SHOULD ALWAYS BE USED!**

STOP!

We recommend completing all test procedures before going forward. If you have not completed those sections, please go back now and complete them.

Also, be sure you have read the *Installation Considerations* on Page 4.

9 Install system

Step A - Make sure all wires are connected as in Step 3.
Use at least 16 AWG copper wire for the earth ground connection. Avoid installing in areas close to large motors, electrical machinery, RF garage door openers, etc.

Step B - Dig a trench for the probe and cable.
Follow the figure entitled *Probe Installation Next to a Driveway* for correct layout of the AutoSense Vehicle Detection System. The first probe should be placed at least 25 feet from the edge of open gate.

Step C - Lay the probe and cable in the trench.
Be careful not to damage the probe cable during installation and burial. We strongly recommend using conduit to protect the cable.

NOTE: DO NOT RUN THE PROBE CABLE IN THE SAME TRENCH WITH ELECTRICAL SERVICE CABLE (LOW-VOLTAGE/CURRENT IS OK).

Step D - Field test the system again (Step 7) to ensure proper operation before burying the probe and cable.

Step E - Carefully backfill the trench.

Step F - Set the relay latch time on the controller if a longer relay latch time is required by your particular gate/door system.
The default relay latch time is approximately 1 second. If 6 seconds is needed, simply cut the Relay Latch Time Jumper on the controller. See the What's what? section on Page 1 for the location of the jumper.

Step G - Close the gate opener, door opener, or other enclosure.

NOTE: FOR INSTALLATION IN A DRIVEWAY, THE PROBE(S) SHOULD BE BURIED PERPENDICULAR TO THE DIRECTION OF TRAFFIC.

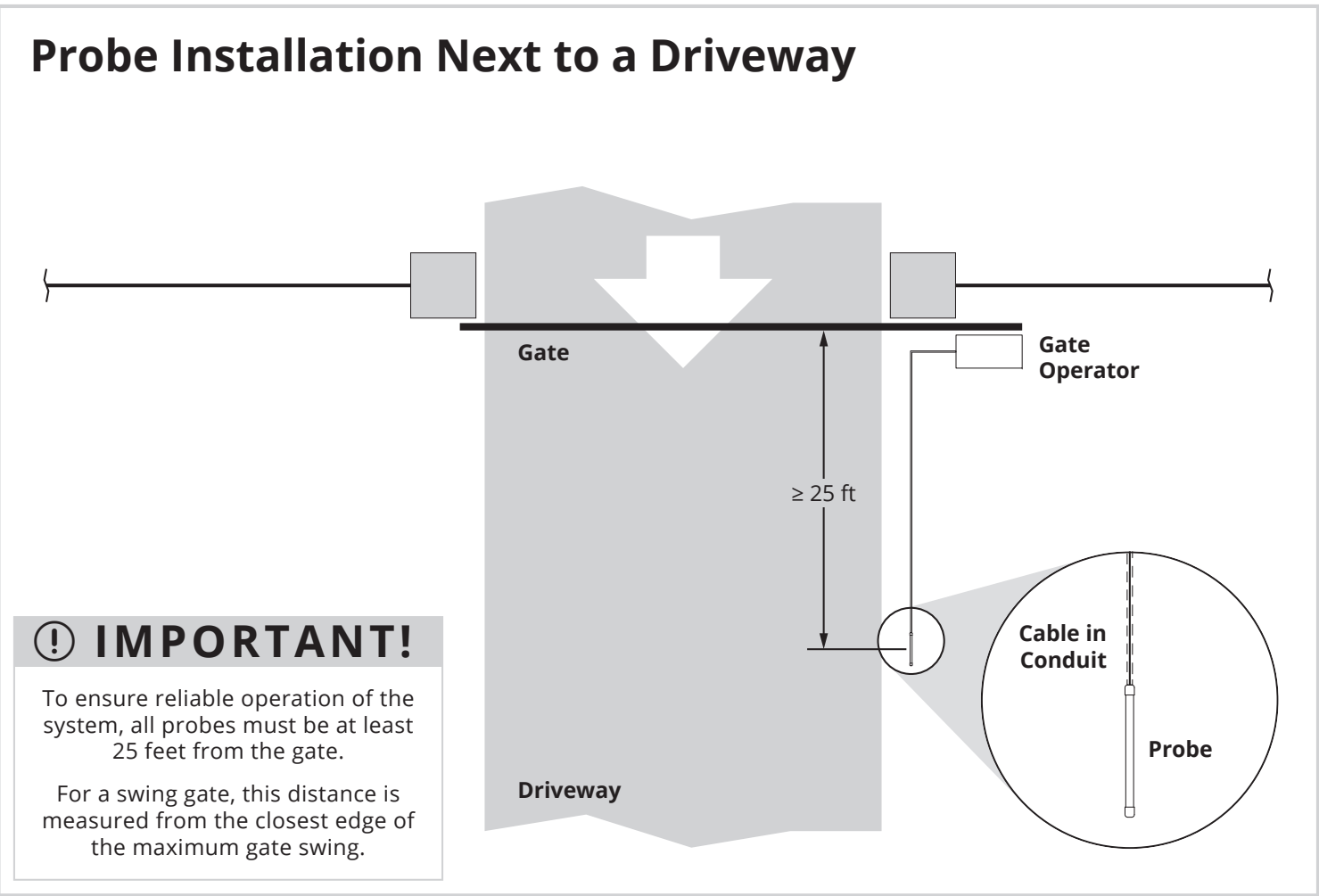

INSTALLATION COMPLETE!

Your system is ready to use.

WARNING!

AUTOMATIC GATES CAN CAUSE SERIOUS INJURY OR DEATH!

ALWAYS CHECK that the **GATE PATH IS CLEAR BEFORE OPERATING!**

REVERSING or other **SAFETY DEVICES SHOULD ALWAYS BE USED!**

B Troubleshooting

False Tripping

Two basic causes for false tripping of the AutoSense Vehicle Detection System exist: those related to the operating environment and those related to failure of the probe or controller. False tripping related to the operating environment is usually caused by faulty grounding, power lines, transformers too close to the probe or cable, or detection of fast-moving vehicles outside the intended sensing area of the probe. Carefully check these possibilities before assuming a probe or controller malfunction.

Most false tripping attributable to the probe system is caused by moisture in the probe or cable. This moisture can enter the cable from a small nick in the outer jacket incurred during installation or grounds maintenance. This problem may be difficult to verify with an ohmmeter/multimeter. Check the probe(s) and controller by performing the procedures listed here. If the problem is not apparent from these tests, then it is usually safe to assume that the cable has moisture in it.

Isolate the probe from the controller by disconnecting it from the circuit board. If the controller trips with the probe disconnected, the problem is with the circuit board or with the input power.

NOTE: IT IS NORMAL FOR THE AUTOSENSE CONTROLLER TO TRIP WHEN THE CIRCUIT BOARD TERMINALS ARE TOUCHED.

Testing the Probe

Step 1 - Disconnect the probe wires from the controller.

Step 2 - Measure the resistance between the probe shield wire and the probe red (white) wire. Do the same with the probe black (blue) wire.

Use a good-quality ohmmeter/multimeter on the highest ohms scale (must be at least 20 MΩ full scale for a valid test). The meter reading should be infinity (totally open) for both measurements. If it is not, the cable either contains moisture or has been partially crushed.

Step 3 - Measure the resistance between the probe red (white) wire and the probe black (blue) wire.

The reading should be 750 Ω ± 10%. If not, the probe is defective. If multiple probes are wired in series, the resistance reading at the controller end should be: *number of probes* x 750 (± 10%).

Testing the Controller

Step 1 - Disconnect the probe from the controller.

NOTE: IT IS NORMAL FOR THE AUTOSENSE CONTROLLER TO TRIP WHEN THE WIRES ARE BEING DISCONNECTED.

Step 2 - Verify the input voltage is 11 to 14 VDC at the POWER terminals.

Voltages outside this range will result in unsatisfactory operation.

Step 3 - Turn the Gain Control to a half position, connect an ohmmeter/multimeter between the COM and N/O terminals, and momentarily short the SIG + and SHLD terminals.

The relay should click, and the ohmmeter/multimeter should indicate continuity. If neither happens (and the input voltage is within specifications), the controller is faulty.

Step 4 - Use a high-impedance DC voltmeter/multimeter to measure the DC voltage between the SHLD (-) and SIG + (+) terminals and between the SHLD and SIG - terminals.

The voltage reading should be around 2.4 to 2.6 VDC. If the voltage is significantly lower, or if there is no reading, the controller is faulty.

Step 5 - Check the DC voltage between the Test Point (T.P.) contact and the EARTH GROUND terminal.

With the probe disconnected and the Gain Control turned fully clockwise (maximum sensitivity), the voltage reading should be around 2.4 to 2.6 VDC and steady (allow 30 seconds for the voltage to become steady). If the voltage is outside this range or is not steady, the controller is faulty.

Optional Step - Disconnect all three probe wires (Complete only if the controller relay is cycling continuously)

This step tests for an open probe cable, an open shield wire, or moisture in the cable. If the relay cycling stops, look for an opening in the shield wire at a splice, if there is one, or at the controller end. Be sure the **Testing the Probe** procedure has been completed.

NEED HELP



Call (972) 474-6390

Email techsupport@securitybrandsinc.com

We are available **Mon-Fri / 8am-5pm Central**



SECURITY BRANDS INC™
your *partner* in access control