

ADVANTAGE ONE



26-1000

1,000-CODE KEYPAD WITH SMART LEDS

FEATURES

- Control up to 2 gates/doors
- 1,000 four-digit code capacity
- Latch code
- Sleep code
- Personal master code
- Variable relay time
- Silent mode
- Timed anti-passback
- Event input
- Audible-tone and Smart LED feedback
- Tricolor-LED-backlit keypad



ADVANTAGE

RELIABLE ACCESS CONTROL FOR OVER 40 YEARS

NO-NONSENSE OPERATION

If you're looking for keypad that are easy to program and easy to use, look no further!

SMART LEDS

The keypad backlights change color depending on the current state of the keypad, making using it exceptionally easy.

STURDY AND DURABLE

All our products are made from high-quality materials that will last for years to come.

PROGRAMMING YOU KNOW

Quick, simple, and familiar, the basic programming steps on the keypad are identical to those on all our keypads.



SPECIFICATIONS

PHYSICAL

Dimensions	5.22"(H) x 5.22"(W) x 5.10"(D)
Shipping Weight	4 lbs.

ELECTRICAL

Input	12–24 VAC/DC power supply not included
Current Draw	less than 67 mA @ 12 VDC less than 35 mA @ 24 VDC with relay latched and backlit components on

RELAY

Contact Rating	3 A @ 24 V / 3 A @ 120 V DC Load / AC Load
Variable Relay Time	1–9999 seconds

ENVIRONMENTAL

Operating Temperature	-13 to 158 °F
-----------------------	---------------

MOUNTING

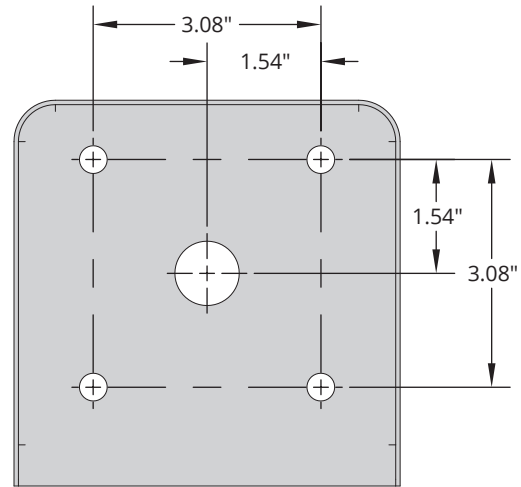

HOLE SIZES

Wiring pass through	0.88"
Mounting holes (x4)	0.38"

Unit includes mounting hardware.

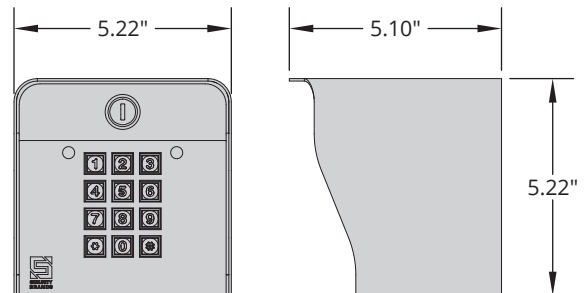

KEYPAD LED FEEDBACK

Intuitive LED feedback pairs with standard audible tones to provide simple visual cues for every keypad interaction.

- | | |
|---------------|------------------|
| Ready | Programming Mode |
| Valid entry | Relay A Latched |
| Invalid entry | Relay B Latched |

For more information, visit us online:
securitybrandsinc.com

